

# Quick Reference Guide

## Kurzanleitung

## Guide de référence rapide

## Beknopte Bedieningshandleiding

## Guida di riferimento rapido

## Guía de referencia rápida

## Guia de referência rápida

## Краткий справочник

brother



Be sure to read this document before using the machine.  
We recommend that you keep this document nearby for future reference.

Bitte lesen Sie diese Anleitung, bevor Sie mit der Maschine arbeiten.  
Es wird empfohlen, diese Anleitung griffbereit aufzubewahren, damit Sie jederzeit darin nachschlagen können.

Veillez à lire ce document avant d'utiliser la machine.  
Nous vous conseillons de conserver ce document à portée de main pour vous y référer ultérieurement.

Lees dit document voordat u de machine gebruikt.  
Houd dit document bij de hand, zodat u het kunt raadplegen.

Leggere questo documento prima di utilizzare la macchina.  
Si consiglia di conservare questo documento nelle vicinanze per un eventuale riferimento futuro.

Lea este documento antes de utilizar la máquina.  
Recomendamos que tenga este documento a mano por si necesita consultarlo más adelante.

Certifique-se de ler este documento antes de utilizar a máquina.  
Recomendamos guardar este documento em um lugar de fácil acesso para futuras referências.

Обязательно прочитайте этот документ перед началом работы на машине!  
Рекомендуется хранить данный документ в удобном месте, чтобы он был доступен для справок.

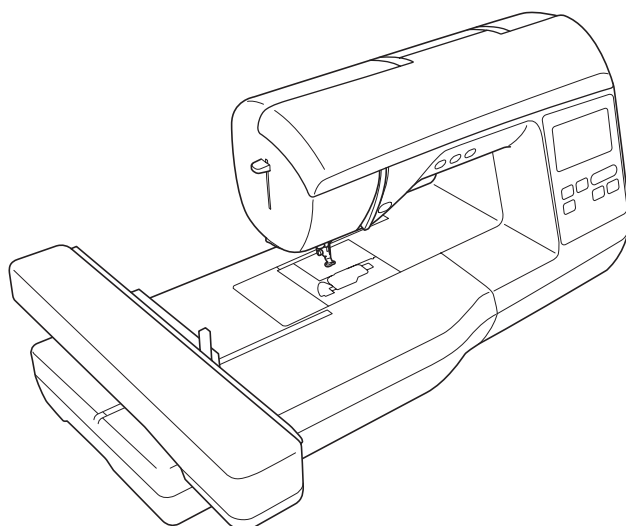

**Before using your machine for the first time please read the “IMPORTANT SAFETY INSTRUCTIONS” in the Operation Manual.**

Refer to the operation manual for detailed instructions.

In this guide, English screens are used for basic explanations.

For details on the built-in embroidery patterns, refer to the Embroidery Design Guide.

**Bevor Sie die Maschine zum ersten Mal verwenden, lesen Sie bitte „WICHTIGE SICHERHEITSHINWEISE“ in der Bedienungsanleitung.**

Ausführliche Hinweise finden Sie in der Bedienungsanleitung.

In dieser Anleitung werden für die grundlegenden Erläuterungen englischsprachige Bildschirme verwendet.

Weitere Informationen zu den internen Stickmustern finden Sie in dem Stickmuster-Katalog.

**Avant d'utiliser votre machine pour la première fois, veuillez lire les « INSTRUCTIONS DE SÉCURITÉ IMPORTANTES » indiquées dans le manuel d'instructions.**

Reportez-vous au manuel d'instructions pour des informations détaillées.

Les écrans de ce guide sont en anglais pour les explications de base.

Pour plus de détails sur les motifs de broderie intégrés, consultez le guide de motifs de broderie.

**Lees – voordat u de machine de eerste keer gebruikt – de “BELANGRIJKE VEILIGHEIDSINSTRUCTIES” in de Bedieningshandleiding.**

In de bedieningshandleiding vindt u uitvoerige aanwijzingen.

In deze gids worden Engelse schermen gebruikt bij de uitleg van basisbewerkingen.

Meer bijzonderheden over de ingebouwde borduurpatronen vindt u in de Borduurmotieven handleiding.

**Prima di utilizzare la macchina per la prima volta, leggere “IMPORTANTI ISTRUZIONI DI SICUREZZA” nel manuale d'istruzione.**

Per le istruzioni dettagliate, consultare il manuale di istruzioni.

Nella presente guida si utilizzano le schermate in inglese per le spiegazioni di base.

Per i dettagli sui motivi da ricamo incorporati, consultare la Guida ai disegni da ricamo.

**Antes de utilizar la máquina por primera vez, lea las “INSTRUCCIONES DE SEGURIDAD IMPORTANTES” en el Manual de instrucciones.**

Consulte las instrucciones detalladas en el manual de instrucciones.

En esta guía, para las explicaciones básicas se utilizan pantallas en inglés.

Para más detalles acerca de los patrones de bordado embutidos, consulte la Guía de diseños de bordado.

**Antes de utilizar a sua máquina pela primeira vez, leia as “INSTRUÇÕES DE SEGURANÇA IMPORTANTES” no Manual de Operações.**

Consulte o manual de operações para obter instruções detalhadas.

Neste manual, as telas em inglês são usadas para as explicações básicas.

Para obter detalhes sobre os padrões de bordado incluídos, consulte o Guia de Design de Bordado.

**Перед первым использованием машины прочитайте раздел “ВАЖНЫЕ ИНСТРУКЦИИ ПО БЕЗОПАСНОСТИ” в Руководстве пользователя.**

Подробные инструкции см. в руководстве пользователя.

В данном руководстве в качестве иллюстраций используются англоязычные экраны.

Подробная информация о встроенных рисунках для вышивания приведена в Руководстве по дизайнам для вышивания.

## Contents

Accessories .....	3
◆ Included Accessories .....	3
◆ Optional Accessories .....	3
Bobbin Winding and Setting .....	11
Upper Threading .....	13
Preparing to Embroider .....	15
Selecting Embroidery Patterns .....	17

## Table des matières

Accessoires .....	5
◆ Accessoires inclus .....	5
◆ Accessoires en option .....	5
Bobinage et réglage de la canette .....	11
Enfilage supérieur .....	13
Préparation de la broderie .....	15
Sélection des motifs de broderie .....	17

## Sommario

Accessori .....	7
◆ Accessori in dotazione .....	7
◆ Accessori opzionali .....	7
Avvolgimento spolina e caricamento .....	11
Infilatura superiore .....	13
Preparativi per il ricamo .....	15
Selezione di ricami .....	17

## Índice

Acessórios .....	9
◆ Acessórios incluídos .....	9
◆ Acessórios opcionais .....	9
Configuração e enrolamento da bobina .....	11
Passagem da linha superior .....	13
Preparação para bordar .....	15
Seleção de padrões de bordado .....	17

## Inhalt

Zubehör .....	3
◆ Mitgeliefertes Zubehör .....	3
◆ Optionales Zubehör .....	3
Aufspulen des Unterfadens und Einstellung .....	11
Einfädeln des Oberfadens .....	13
Vorbereitung zum Sticken .....	15
Auswählen von Stickmustern .....	17

## Inhoudsopgave

Accessoires .....	5
◆ Bijgeleverde accessoires .....	5
◆ Optionele accessoires .....	5
Opwinden en instellen van de spoel .....	11
Inrijgen van de bovendraad .....	13
Voorbereidingen voor borduren .....	15
Borduurpatronen selecteren .....	17

## Contenido

Accesorios .....	7
◆ Accesorios incluidos .....	7
◆ Accesorios opcionales .....	7
Bobinado y ajuste .....	11
Hilo superior .....	13
Preparativos para bordar .....	15
Seleccionar patrones de bordado .....	17

## Содержание

Принадлежности .....	9
◆ Принадлежности в комплекте поставки .....	9
◆ Дополнительные принадлежности .....	9
Намотка и установка шпульки .....	11
Заправка верхней нити .....	13
Подготовка к вышиванию .....	15
Выбор рисунков для вышивания .....	17



# Accessories

# Zubehör

## ◆ Included Accessories

## ◆ Mitgeliefertes Zubehör

1.	2.*1	3.	4.*2	5.
6.	7.	8.	9.	10.
11.	12.	13.	14.	15.
16.	17.	18.	19.	20.
21.	22.	23.	24.	

\*1 75/11 3 needles  
90/14 1 needle  
\*2 For U.S.A. and Canada only

\*1 3 Nadeln 75/11  
1 Nadel 90/14  
\*2 Nur für USA und Kanada.

## ◆ Optional Accessories

## ◆ Optionales Zubehör

1.	2.	3.	4.	5.
6.	7.	8.		

## ◆ Included Accessories

No.	Part Name	Part Code	
		Americas	Others
1	Embroidery foot "U"	XD0313-051	
2	Needle set	X59535-051	
3	Bobbin (4) (One is on machine.)	SA156*3	SFB: XA5539-151
4	Bobbin center pin and instruction sheet	XF5048-001 (U.S.A./ Canada)	—
5	Seam ripper	XF4967-001	
6	Scissors	XC1807-121	
7	Cleaning brush	X59476-051	
8	Screwdriver (large)	XC4237-021	
9	Screwdriver (small)	X55468-051	
10	L-shaped screwdriver	XG0918-001	
11	Disc-shaped screwdriver	XC1074-051	
12	Spool cap (large)	130012-024	
13	Spool cap (medium) (on machine)	XE1372-001	
14	Spool cap (small)	130013-124	
15	Thread spool insert (mini king thread spool)	XA5752-121	
16	Spool net	XA5523-020	
17	Bobbin case (no color on the screw)	XG0871-001	
18	Embroidery frame set (extra large) 26 cm (H) × 16 cm (W) (10-1/4 inches (H) × 6-1/4 inches (W))	SA441/ EF81	EF81: XC9763-152
19	Poly 90 weight bobbin thread	EBT-PE	EBT-PEN: XC5996-001
20	Accessory bag	XC4487-021	
21	Dust cover	XF9531-001	
22	Operation manual	Contact your authorized Brother dealer.	
23	Quick reference guide		
24	Embroidery Design Guide		

\*3 SA156 is Class15 type bobbin.

## ◆ Mitgeliefertes Zubehör

Nr.	Teilebezeichnung	Bestellnummer	
		Nord- und Südamerika	Andere
1	Stickfuß „U“	XD0313-051	
2	Nadelsatz	X59535-051	
3	Spule (4) (Eine ist in der Maschine.)	SA156*3	SFB: XA5539-151
4	Spulenführungszapfen und Gebrauchsanleitung	XF5048-001 (USA/ Kanada)	—
5	Pfeiltrenner	XF4967-001	
6	Schere	XC1807-121	
7	Reinigungspinsel	X59476-051	
8	Schraubendreher (groß)	XC4237-021	
9	Schraubendreher (klein)	X55468-051	
10	L-förmiger Schraubendreher	XG0918-001	
11	Scheibenförmiger Schraubendreher	XC1074-051	
12	Garnrollenkappe (groß)	130012-024	
13	Garnrollenkappe (mittel) (in der Maschine)	XE1372-001	
14	Garnrollenkappe (klein)	130013-124	
15	Garnrolleneinsatz (Mini-King-Garnrolle)	XA5752-121	
16	Spulennetz	XA5523-020	
17	Spulenkapsel (ohne Schraubenmarkierung)	XG0871-001	
18	Stickrahmenset (extragroß) 26 cm (H) × 16 cm (W) (10-1/4 Zoll (H) × 6-1/4 Zoll (W))	SA441/ EF81	EF81: XC9763-152
19	Unterfaden der Gewichtsklasse Poly 90	EBT-PE	EBT-PEN: XC5996-001
20	Zubehörtasche	XC4487-021	
21	Staubabdeckung	XF9531-001	
22	Bedienungsanleitung	Wenden Sie sich an Ihr Brother-Fachgeschäft.	
23	Kurzanleitung		
24	Stickmuster-Katalog		

\*3 SA156 ist eine Class15-Spule.

## ◆ Optional Accessories

The following are available as optional accessories to be purchased separately from your authorized Brother dealer.

No.	Part Name	Part Code	
		Americas	Others
1	Embroidery frame set (large) 18 cm (H) × 13 cm (W) (7 inches (H) × 5 inches (W))	SA439/ EF75	EF75: XC8481-152
2	Embroidery frame set (medium) 10 cm (H) × 10 cm (W) (4 inches (H) × 4 inches (W))	SA438/ EF74	EF74: XC8480-152
3	Embroidery frame set (small) 2 cm (H) × 6 cm (W) (1 inch (H) × 2-1/2 inches (W))	SA437/ EF73	EF73: XC8479-152
4	Border embroidery frame set 18 cm (H) × 10 cm (W) (7 inches (H) × 4 inches (W))	SABF6000D (U.S.A.) SABF6000DC (Canada)	BF2: XE5059-001
5	Square embroidery frame 15 cm (H) × 15 cm (W) (6 inches (H) × 6 inches (W))	SA448 (U.S.A.) SA448C (Canada)	SEF150: XF4163-001
6	Stabilizer material for embroidery	SA519	BM3: XE0806-001
7	Water soluble stabilizer	SA520	BM5: XE0615-001
8	Spool stand	SA563 (U.S.A.)	XG0900-001
		SA563C (Canada)	TS7: XG0900-001 TS7AP: XG0902-001

## ◆ Optionales Zubehör

Folgendes Sonderzubehör ist separat bei Ihrem Brother-Vertragshändler erhältlich.

Nr.	Teilebezeichnung	Bestellnummer	
		Nord- und Südamerika	Andere
1	Stickrahmenset (groß) 18 cm (H) × 13 cm (W) (7 Zoll (H) × 5 Zoll (W))	SA439/ EF75	EF75: XC8481-152
2	Stickrahmenset (mittel) 10 cm (H) × 10 cm (W) (4 Zoll (H) × 4 Zoll (W))	SA438/ EF74	EF74: XC8480-152
3	Stickrahmenset (klein) 2 cm (H) × 6 cm (W) (1 Zoll (H) × 2-1/2 Zoll (W))	SA437/ EF73	EF73: XC8479-152
4	Bordüren-Stickrahmenset 18 cm (H) × 10 cm (W) (7 Zoll (H) × 4 Zoll (W))	SABF6000D (USA) SABF6000DC (Kanada)	BF2: XE5059-001
5	Quadratischer Stickrahmen 15 cm (H) × 15 cm (W) (6 Zoll (H) × 6 Zoll (W))	SA448 (USA) SA448C (Kanada)	SEF150: XF4163-001
6	Unterlegmaterial für Stickereien	SA519	BM3: XE0806-001
7	Wasserlösliche Stickfolie	SA520	BM5: XE0615-001
8	Garnrollenständer	SA563 (USA) SA563C (Kanada)	TS7: XG0900-001 TS7AP: XG0902-001



## Accessoires

## Accessoires

### ◆ Accessoires inclus

### ◆ Bijgeleverde accessoires

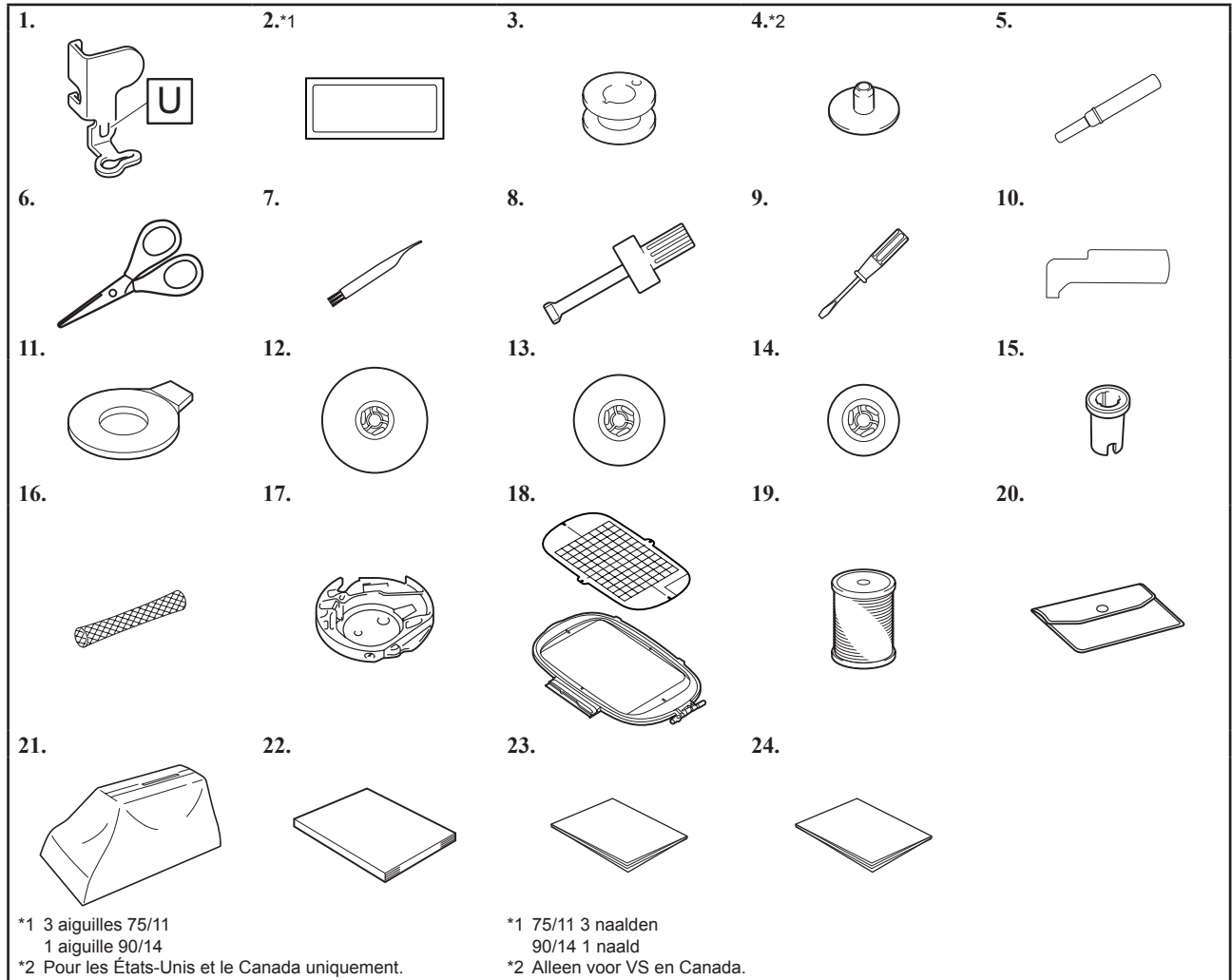

### ◆ Accessoires en option

### ◆ Optionele accessoires

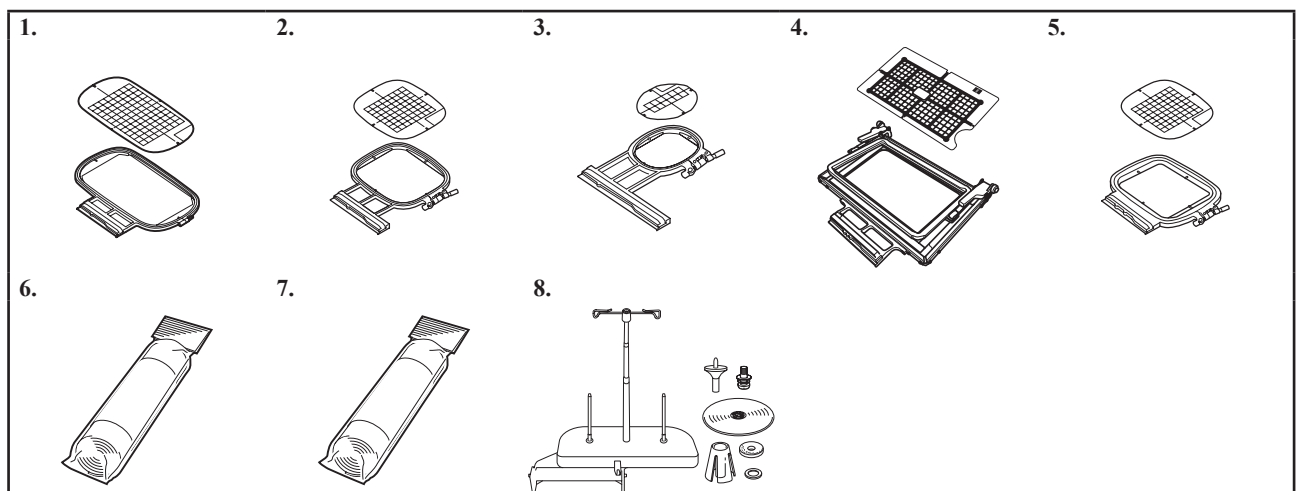

## ◆ Accessoires inclus

N°	Nom de la pièce	Code de la pièce	
		Continent américain	Autres
1	Pied de broderie « U »	XD0313-051	
2	Jeu d'aiguilles	X59535-051	
3	Canette x 4 (l'une se trouve sur la machine.)	SA156*3	SFB: XA5539-151
4	Pivot de canette et fiche d'instructions	XF5048-001 (États-Unis/ Canada)	—
5	Découpeur	XF4967-001	
6	Ciseaux	XC1807-121	
7	Brosse de nettoyage	X59476-051	
8	Tournevis (grand)	XC4237-021	
9	Tournevis (petit)	X55468-051	
10	Tournevis en forme de L	XG0918-001	
11	Tournevis en forme de disque	XC1074-051	
12	Couvercle de bobine (grand)	130012-024	
13	Couvercle de bobine (moyen) (sur la machine)	XE1372-001	
14	Couvercle de bobine (petit)	130013-124	
15	Centre amovible pour bobine de fil (bobine de fil mini/très grand)	XA5752-121	
16	Filet de la bobine	XA5523-020	
17	Boîtier de la canette (sans couleur sur la vis)	XG0871-001	
18	Jeu de cadre de broderie (très grand) H 26 cm x L 16 cm (H 10-1/4" / pouces x L 6-1/4" / pouces)	SA441/ EF81	EF81: XC9763-152
19	Fil de canette à broder poly n°90	EBT-PE	EBT-PEN: XC5996-001
20	Sac d'accessoires	XC4487-021	
21	Housse	XF9531-001	
22	Manuel d'instructions	Contactez votre revendeur Brother agréé.	
23	Guide de référence rapide		
24	Guide de motifs de broderie		

\*3 SA156 est une canette de catégorie 15.

## ◆ Bijgeleverde accessoires

Nr.	Onderdeel	Onderdeelcode	
		Het Amerikaanse continent	Overige regio's
1	Borduurovoet "U"	XD0313-051	
2	Naaldsetje	X59535-051	
3	Spoel x 4 (één spoel is in de machine geplaatst.)	SA156*3	SFB: XA5539-151
4	Spoelspil in instructievel	XF5048-001 (VS/Canada)	—
5	Tornmesje	XF4967-001	
6	Schaar	XC1807-121	
7	Schoonmaakborsteltje	X59476-051	
8	Schroevendraaier (groot)	XC4237-021	
9	Schroevendraaier (klein)	X55468-051	
10	L-vormige schroevendraaier	XG0918-001	
11	Schijfvormige schroevendraaier	XC1074-051	
12	Kloshouder (groot)	130012-024	
13	Kloshouder (medium) (op machine)	XE1372-001	
14	Kloshouder (klein)	130013-124	
15	Garenklos hulpinzet (bij mini- of kingsize garenklos)	XA5752-121	
16	Klosnetje	XA5523-020	
17	Spoelhuis (geen kleur op de schroef)	XG0871-001	
18	Borduuraamset (extra groot) 26 cm (H) x 16 cm (B) (10-1/4 inch (H) x 6-1/4 inch (B))	SA441/ EF81	EF81: XC9763-152
19	Poly onderdraad, dikte 90	EBT-PE	EBT-PEN: XC5996-001
20	Accessoires tasje	XC4487-021	
21	Stoffhoes	XF9531-001	
22	Bedieningshandleiding	Neem contact op met uw erkende Brother-dealer.	
23	Beknopte bedieningshandleiding		
24	Borduurmotieven handleiding		

\*3 SA156 is een spoeltype van klasse 15.

## ◆ Accessoires en option

Les éléments suivants sont des accessoires en option vendus séparément par votre revendeur Brother agréé.

N°	Nom de la pièce	Code de la pièce	
		Continent américain	Autres
1	Jeu de cadre de broderie (grand) H 18 cm x L 13 cm (H 7" / pouces x L 5" / pouces)	SA439/ EF75	EF75: XC8481-152
2	Jeu de cadre de broderie (moyen) H 10 cm x L 10 cm (H 4" / pouces x L 4" / pouces)	SA438/ EF74	EF74: XC8480-152
3	Jeu de cadre de broderie (petit) H 2 cm x L 6 cm (H 1" / pouce x L 2-1/2" / pouces)	SA437/ EF73	EF73: XC8479-152
4	Jeu de cadre de broderie de bord H 18 cm x L 10 cm (H 7" / pouces x L 4" / pouces)	SABF6000D (États-Unis) SABF6000DC (Canada)	BF2: XE5059-001
5	Cadre de broderie carré H 15 cm x L 15 cm (H 6" / pouces x L 6" / pouces)	SA448 (États-Unis) SA448C (Canada)	SEF150: XF4163-001
6	Renfort de broderie	SA519	BM3: XE0806-001
7	Renfort de broderie soluble	SA520	BM5: XE0615-001
8	Porte multi-bobines	SA563 (États-Unis) SA563C (Canada)	TS7: XG0900-001 TS7AP: XG0902-001

## ◆ Optionele accessoires

Optionele accessoires, apart verkrijgbaar bij uw officiële Brother dealer.

Nr.	Onderdeel	Onderdeelcode	
		Het Amerikaanse continent	Overige regio's
1	Borduuraamset (groot) 18 cm (H) x 13 cm (B) (7 inch (H) x 5 inch (B))	SA439/ EF75	EF75: XC8481-152
2	Borduuraamset (medium) 10 cm (H) x 10 cm (B) (4 inch (H) x 4 inch (B))	SA438/ EF74	EF74: XC8480-152
3	Borduuraamset (klein) 2 cm (H) x 6 cm (B) (1 inch (H) x 2-1/2 inch (B))	SA437/ EF73	EF73: XC8479-152
4	Randborduurraamset 18 cm (H) x 10 cm (B) (7 inch (H) x 4 inch (B))	SABF6000D (VS) SABF6000DC (Canada)	BF2: XE5059-001
5	Vierkant borduurraam 15 cm (H) x 15 cm (B) (6 inch (H) x 6 inch (B))	SA448 (VS) SA448C (Canada)	SEF150: XF4163-001
6	Steunstof voor borduurwerk	SA519	BM3: XE0806-001
7	Wateroplosbare steunstof	SA520	BM5: XE0615-001
8	Klossenstandaard	SA563 (VS) SA563C (Canada)	TS7: XG0900-001 TS7AP: XG0902-001



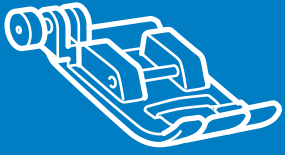

## Accessori

## Accesorios

### ◆ Accessori in dotazione

### ◆ Accesorios incluidos

1.	2.*1	3.	4.*2	5.
6.	7.	8.	9.	10.
11.	12.	13.	14.	15.
16.	17.	18.	19.	20.
21.	22.	23.	24.	

\*1 3 aghi 75/11  
1 ago 90/14  
\*2 Solo per Stati Uniti e Canada.

\*1 3 agujas 75/11  
1 aguja 90/14  
\*2 Solo para EE.UU. y Canadá.

### ◆ Accessori opzionali

### ◆ Accesorios opcionales

1.	2.	3.	4.	5.
6.	7.	8.		



## ◆ Accessori in dotazione

N°	Nome parte	Codice parte	
		Americhe	Varie
1	Piedino per ricamo "U"	XD0313-051	
2	Set di aghi	X59535-051	
3	Spolina (4) (una è sulla macchina.)	SA156*3	SFB: XA5539-151
4	Perno di centraggio spolina e foglio di istruzioni	XF5048-001 (Stati Uniti/ Canada)	—
5	Taglia asole	XF4967-001	
6	Forbici	XC1807-121	
7	Spazzolino di pulizia	X59476-051	
8	Cacciavite (grande)	XC4237-021	
9	Cacciavite (piccolo)	X55468-051	
10	Cacciavite a L	XG0918-001	
11	Cacciavite a disco	XC1074-051	
12	Fermo per rocchetto (grande)	130012-024	
13	Fermo per rocchetto (medio) (sulla macchina)	XE1372-001	
14	Fermo per rocchetto (piccolo)	130013-124	
15	Inserto per rocchetto di filo (rocchetto di filo mini-extra large)	XA5752-121	
16	Retina	XA5523-020	
17	Custodia della spolina (nessun colore sulla vite)	XG0871-001	
18	Set telaio da ricamo (extra large) 26 cm (A) × 16 cm (L) (10-1/4 in (A) × 6-1/4 in (L))	SA441/ EF81	EF81: XC9763-152
19	Filo della spolina di poliestere, peso 90	EBT-PE	EBT-PEN: XC5996-001
20	Borsa accessori	XC4487-021	
21	Copertura parapolvere	XF9531-001	
22	Manuale d'istruzione	Contattare il proprio rivenditore Brother autorizzato.	
23	Guida di riferimento rapido		
24	Guida ai disegni da ricamo		

\*3 SA156 è una spolina del tipo Classe 15.

## ◆ Accesorios incluidos

N°	Nombre de la pieza	Código de la pieza	
		América	Otros
1	Pie de bordado "U"	XD0313-051	
2	Juego de agujas	X59535-051	
3	Bobina (4) (Una está colocada en la máquina.)	SA156*3	SFB: XA5539-151
4	Pasador central de la bobina y hoja de instrucciones	XF5048-001 (EE.UU./ Canadá)	—
5	Abreojales	XF4967-001	
6	Tijeras	XC1807-121	
7	Cepillo de limpieza	X59476-051	
8	Destornillador (grande)	XC4237-021	
9	Destornillador (pequeño)	X55468-051	
10	Destornillador en forma de L	XG0918-001	
11	Destornillador de disco	XC1074-051	
12	Tapa del carrete (grande)	130012-024	
13	Tapa del carrete (mediana) (en la máquina)	XE1372-001	
14	Tapa de carrete (pequeña)	130013-124	
15	Inserción del carrete de hilo (carrete de hilo "mini king")	XA5752-121	
16	Red para carrete	XA5523-020	
17	Caja de la bobina (sin color en el tornillo)	XG0871-001	
18	Juego de bastidor de bordado (extra grande) 26 cm (Alt.) × 16 cm (Anch.) (10-1/4 pulgadas (Alt.) × 6-1/4 pulgadas (Anch.))	SA441/ EF81	EF81: XC9763-152
19	Hilo de la bobina de gramaje poly 90	EBT-PE	EBT-PEN: XC5996-001
20	Bolsa de accesorios	XC4487-021	
21	Funda	XF9531-001	
22	Manual de instrucciones	Póngase en contacto con su distribuidor Brother autorizado.	
23	Guía de referencia rápida		
24	Guía de diseños de bordado		

\*3 SA156 Es de bobina clase tipo 15.

## ◆ Accessori opzionali

Di seguito si elencano i componenti disponibili come accessori opzionali da acquistare separatamente presso il proprio rivenditore Brother autorizzato.

N°	Nome parte	Codice parte	
		Americhe	Varie
1	Set telaio da ricamo (grande) 18 cm (A) × 13 cm (L) (7 in (A) × 5 in (L))	SA439/ EF75	EF75: XC8481-152
2	Set telaio da ricamo (medio) 10 cm (A) × 10 cm (L) (4 in (A) × 4 in (L))	SA438/ EF74	EF74: XC8480-152
3	Set telaio da ricamo (piccolo) 2 cm (A) × 6 cm (L) (1 in (A) × 2-1/2 in (L))	SA437/ EF73	EF73: XC8479-152
4	Set telaio da ricamo per bordi 18 cm (A) × 10 cm (L) (7 in (A) × 4 in (L))	SABF6000D (Stati Uniti) SABF6000DC (Canada)	BF2: XE5059-001
5	Telaio da ricamo quadrato 15 cm (A) × 15 cm (L) (6 in (A) × 6 in (L))	SA448 (Stati Uniti) SA448C (Canada)	SEF150: XF4163-001
6	Materiale stabilizzatore per ricamo	SA519	BM3: XE0806-001
7	Stabilizzatore solubile in acqua	SA520	BM5: XE0615-001
8	Supporto per coni di filato	SA563 (Stati Uniti) SA563C (Canada)	TS7: XG0900-001 TS7AP: XG0902-001

## ◆ Accesorios opcionales

En la tabla siguiente se presentan los accesorios opcionales disponibles que pueden adquirirse por separado en un distribuidor de Brother autorizado.

N°	Nombre de la pieza	Código de la pieza	
		América	Otros
1	Juego de bastidor de bordado (grande) 18 cm (Alt.) × 13 cm (Anch.) (7 pulgadas (Alt.) × 5 pulgadas (Anch.))	SA439/ EF75	EF75: XC8481-152
2	Juego de bastidor de bordado (mediano) 10 cm (Alt.) × 10 cm (Anch.) (4 pulgadas (Alt.) × 4 pulgadas (Anch.))	SA438/ EF74	EF74: XC8480-152
3	Juego de bastidor de bordado (pequeño) 2 cm (Alt.) × 6 cm (Anch.) (1 pulgada (Alt.) × 2-1/2 pulgadas (Anch.))	SA437/ EF73	EF73: XC8479-152
4	Juego de bastidor de bordado para bordes Alt. 18 cm (Alt.) × 10 cm (Anch.) (7 pulgadas (Alt.) × 4 pulgadas (Anch.))	SABF6000D (EE.UU.) SABF6000DC (Canadá)	BF2: XE5059-001
5	Bastidor de bordado cuadrado 15 cm (Alt.) × 15 cm (Anch.) (6 pulgadas (Alt.) × 6 pulgadas (Anch.))	SA448 (EE.UU.) SA448C (Canadá)	SEF150: XF4163-001
6	Material estabilizador para el bordado	SA519	BM3: XE0806-001
7	Estabilizador soluble en agua	SA520	BM5: XE0615-001
8	Pora hilos grande	SA563 (EE.UU.) SA563C (Canadá)	TS7: XG0900-001 TS7AP: XG0902-001

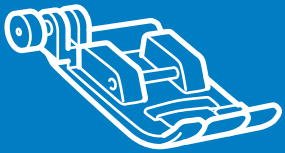

## Acessórios

## Принадлежности

### ◆ Acessórios incluídos

### ◆ Принадлежности в комплекте поставки

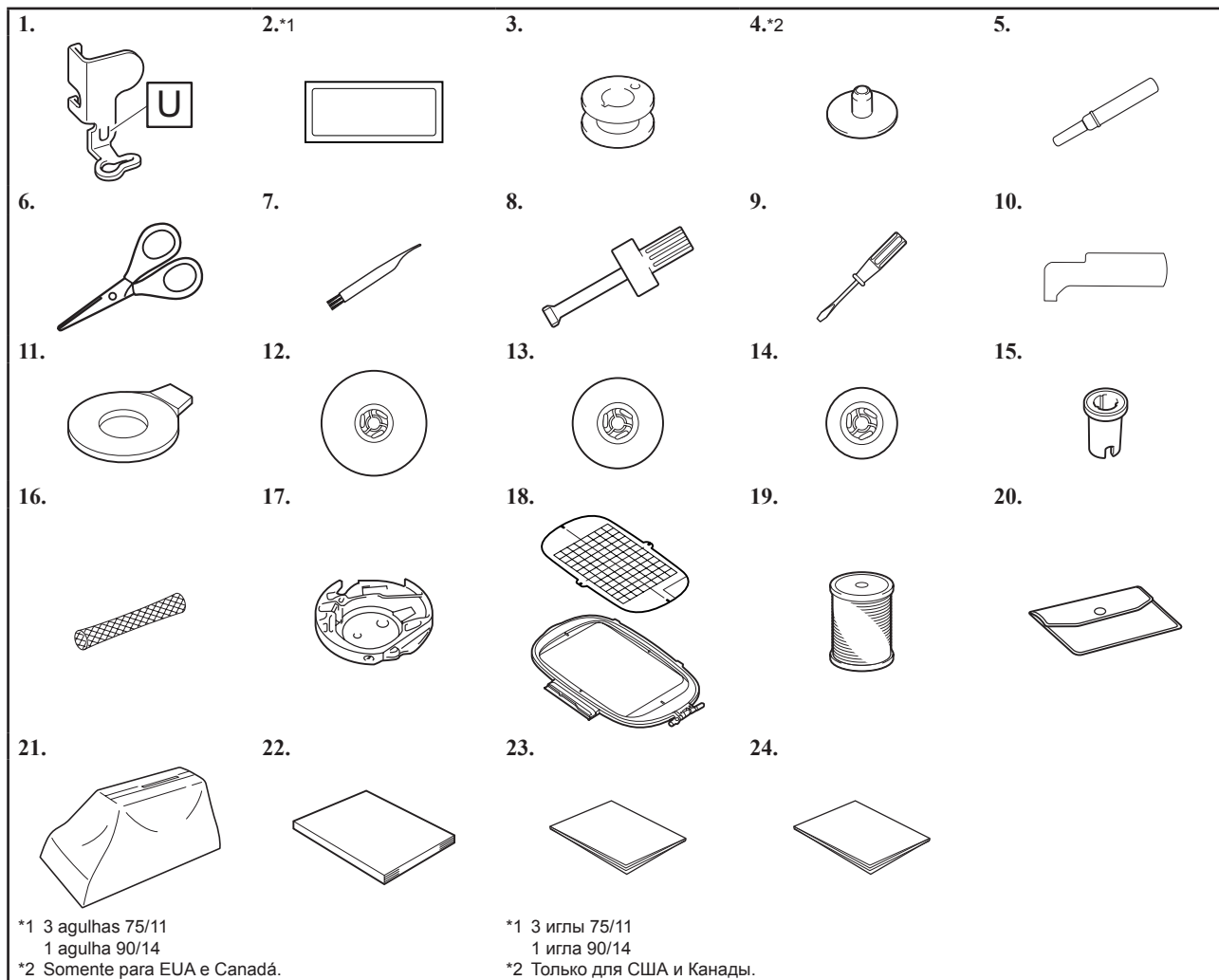

### ◆ Acessórios opcionais

### ◆ Дополнительные принадлежности

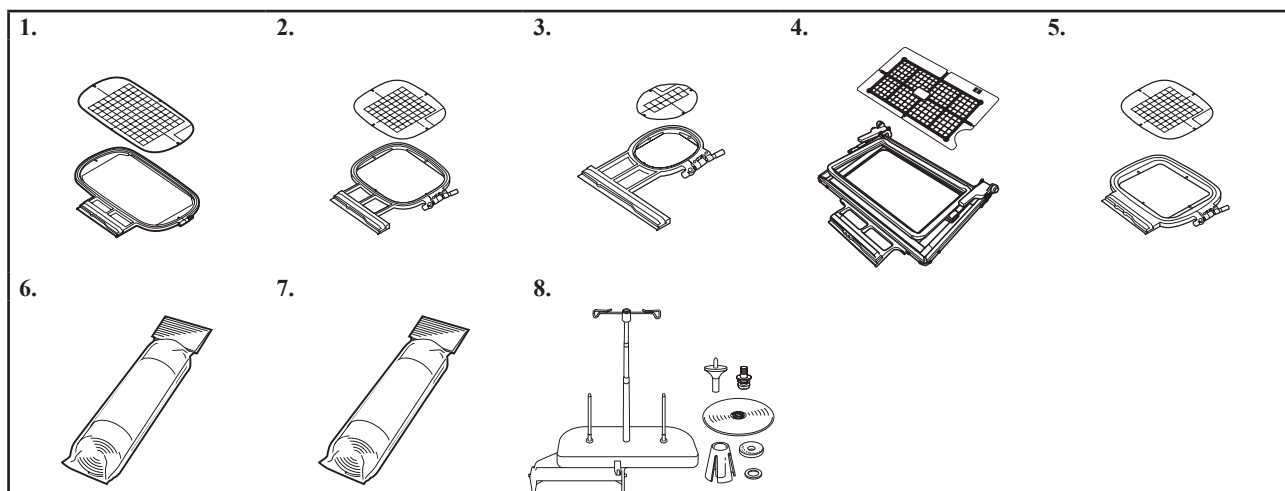

## ◆ Acessórios incluídos

N°	Nome da peça	Código da peça	
		Américas	Outros
1	Calçador de bordado "U"	XD0313-051	
2	Conjunto de agulhas	X59535-051	
3	Bobina (4) (Uma está na máquina.)	SA156*3	SFB: XA5539-151
4	Pino de centralização de bobina e folha de instruções	XF5048-001 (EUA/ Canadá)	—
5	Abridor de costura	XF4967-001	
6	Tesoura	XC1807-121	
7	Escova de limpeza	X59476-051	
8	Chave de fenda (grande)	XC4237-021	
9	Chave de fenda (pequena)	X55468-051	
10	Chave de fenda em forma de L	XG0918-001	
11	Chave de fenda em forma de disco	XC1074-051	
12	Tampa do carretel (grande)	130012-024	
13	Tampa do carretel (média) (na máquina)	XE1372-001	
14	Tampa do carretel (pequena)	130013-124	
15	Inserto do carretel (minicarretel principal)	XA5752-121	
16	Redinha do carretel	XA5523-020	
17	Caixa da bobina (sem cor no parafuso)	XG0871-001	
18	Conjunto de bastidor para bordados (extra grande) 26 cm (A) × 16 cm (L) (10-1/4 polegadas (A) × 6-1/4 polegadas (L))	SA441/ EF81	EF81: XC9763-152
19	Linha de bobina com peso Poly 90	EBT-PE	EBT-PEN: XC5996-001
20	Bolsa de acessórios	XC4487-021	
21	Capa contra pó	XF9531-001	
22	Manual de operações	Entre em contato com o seu revendedor autorizado Brother.	
23	Guia de referência rápida		
24	Guia de design de bordado		

\*3 SA156 é um tipo de bobina da classe 15.

## ◆ Acessórios opcionais

Os acessórios a seguir são opcionais e devem ser adquiridos separadamente em um revendedor autorizado da Brother.

N°	Nome da peça	Código da peça	
		Américas	Outros
1	Conjunto de bastidor para bordados (grande) 18 cm (A) × 13 cm (L) (7 polegadas (A) × 5 polegadas (L))	SA439/ EF75	EF75: XC8481-152
2	Conjunto de bastidor para bordados (médio) 10 cm (A) × 10 cm (L) (4 polegadas (A) × 4 polegadas (L))	SA438/ EF74	EF74: XC8480-152
3	Conjunto de bastidor para bordados (pequeno) 2 cm (A) × 6 cm (L) (1 polegadas (A) × 2-1/2 polegadas (L))	SA437/ EF73	EF73: XC8479-152
4	Conjunto de bastidor de bordar arremate 18 cm (A) × 10 cm (L) (7 polegadas (A) × 4 polegadas (L))	SABF6000D (EUA) SABF6000DC (Canadá)	BF2: XE5059-001
5	Conjunto de bastidor de bordar quadrado 15 cm (A) × 15 cm (L) (6 polegadas (A) × 6 polegadas (L))	SA448 (EUA) SA448C (Canadá)	SEF150: XF4163-001
6	Entretela estabilizadora para bordado	SA519	BM3: XE0806-001
7	Entretela solúvel em água	SA520	BM5: XE0615-001
8	Suporte de carretel	SA563 (EUA) SA563C (Canadá)	TS7: XG0900-001 TS7AP: XG0902-001

## ◆ Pertencimentos em conjunto de entrega

№	Наименование	Код изделия	
		Америка	Другие
1	Лапка для вышивания "U"	XD0313-051	
2	Набор игл	X59535-051	
3	Шпулки (4 шт., одна из них установлена на машине.)	SA156*3	SFB: XA5539-151
4	Центральный стержень для шпулки и лист с инструкциями	XF5048-001 (для США/ для Канады)	—
5	Вспарыватель для петель	XF4967-001	
6	Ножницы	XC1807-121	
7	Щеточка для очистки	X59476-051	
8	Отвертка (большая)	XC4237-021	
9	Отвертка (малая)	X55468-051	
10	Г-образная отвертка	XG0918-001	
11	Дискообразная отвертка	XC1074-051	
12	Колпачок катушки (большой)	130012-024	
13	Колпачок катушки (средний) (установлен на машине)	XE1372-001	
14	Колпачок катушки (малый)	130013-124	
15	Вставка для катушки с нитью (катушки Mini-King)	XA5752-121	
16	Сетка для катушки	XA5523-020	
17	Шпульный колпачок (без цветовой маркировки на винте)	XG0871-001	
18	Набор пялец (сверхбольших), 26 × 16 см (В × Ш)	SA441/ EF81	EF81: XC9763-152
19	Нижняя нить Poly 90wt	EBT-PE	EBT-PEN: XC5996-001
20	Сумка для принадлежностей	XC4487-021	
21	Пылезащитный чехол	XF9531-001	
22	Руководство пользователя	Обратитесь к официальному дилеру Brother.	
23	Краткий справочник		
24	Руководство по дизайнам для вышивания		

\*3 SA156 представляет собой шпулку типа Class15.

## ◆ Дополнительные принадлежности

Перечисленные ниже дополнительные принадлежности можно приобрести отдельно у официального дилера Brother.

№	Наименование	Код изделия	
		Америка	Другие
1	Набор пялец (больших), 18 × 13 см (В × Ш)	SA439/ EF75	EF75: XC8481-152
2	Набор пялец (средних), 10 × 10 см (В × Ш)	SA438/ EF74	EF74: XC8480-152
3	Набор пялец (малых), 2 × 6 см (В × Ш)	SA437/ EF73	EF73: XC8479-152
4	Набор бордюрных пялец, 18 × 10 см (В × Ш)	SABF6000D (для США), SABF6000DC (для Канады)	BF2: XE5059-001
5	Квадратные пяльцы, 15 × 15 см (В × Ш)	SA448 (для США), SA448C (для Канады)	SEF150: XF4163-001
6	Стабилизирующий материал для вышивания	SA519	BM3: XE0806-001
7	Растворимый в воде стабилизирующий материал	SA520	BM5: XE0615-001
8	Стойка для катушек	SA563 (для США), SA563C (для Канады)	TS7: XG0900-001 TS7AP: XG0902-001



# Bobbin Winding and Setting

## Aufspulen des Unterfadens und Einstellung

### Bobinage et réglage de la canette

### Opwinden en instellen van de spoel

### Avvolgimento spolina e caricamento

### Bobinado y ajuste

### Configuração e enrolamento da bobina

### Намотка и установка шпульки

Follow the steps below in numerical order. Refer to the operation manual for detailed instructions.  
 Führen Sie die folgenden Schritte in der numerischen Reihenfolge aus. Ausführliche Hinweise finden Sie in der Bedienungsanleitung.  
 Respectez les étapes ci-dessous, dans l'ordre numérique. Reportez-vous au manuel d'instructions pour des informations détaillées.  
 Volg onderstaande stappen in numerieke volgorde. In de bedieningshandleiding vindt u uitvoerige aanwijzingen.  
 Seguire i passaggi di seguito, in ordine numerico. Per le istruzioni dettagliate, consultare il manuale di istruzioni.  
 Siga los pasos descritos a continuación, en orden numérico. Consulte las instrucciones detalladas en el manual de instrucciones.  
 Siga as etapas abaixo, em ordem numérica. Consulte o manual de operações para obter instruções detalhadas.  
 Выполните описанные ниже действия по порядку номеров. Подробные инструкции см. в руководстве пользователя.

Use only the included bobbin or bobbins of the same type.  
 Verwenden Sie nur die im Lieferumfang enthaltene Spule oder Spulen vom selben Typ.  
 N'utilisez que la canette fournie ou des canettes du même type.  
 Gebruik uitsluitend de bijgeleverde spoel of spoelen van hetzelfde type.  
 Utilizzare solo la bobina o le bobine in dotazione dello stesso tipo.  
 Utilice solo la bobina incluida, o bobinas del mismo tipo.  
 Somente use a bobina incluída ou bobinas do mesmo tipo.  
 Используйте только прилагаемые шпульки или шпульки того же типа.

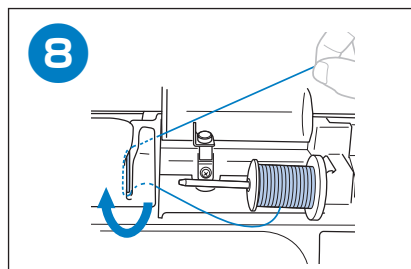
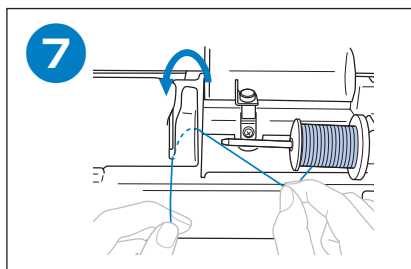
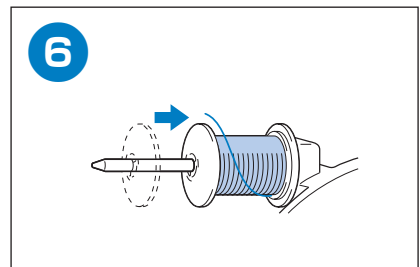
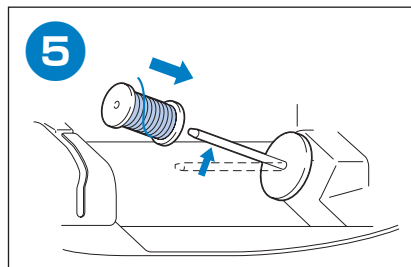
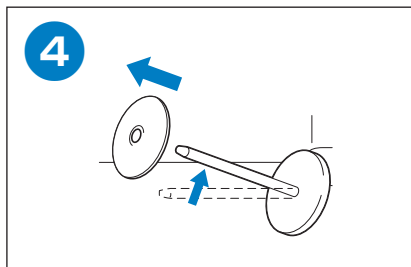
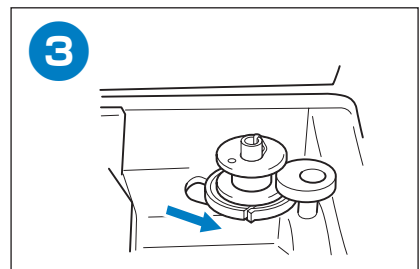
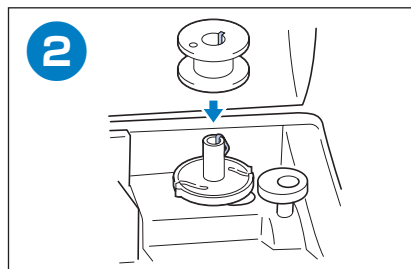
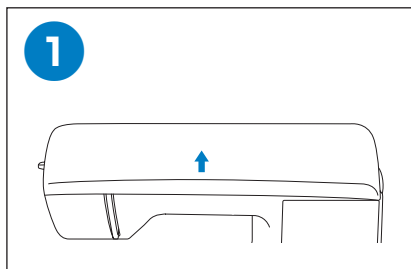
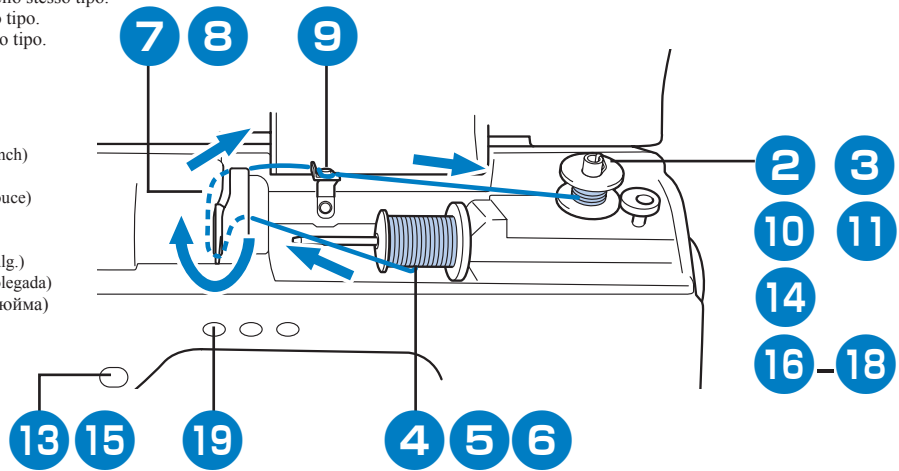
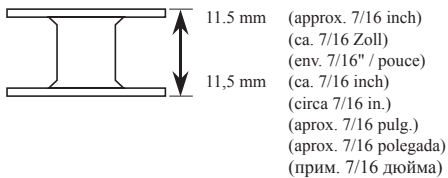

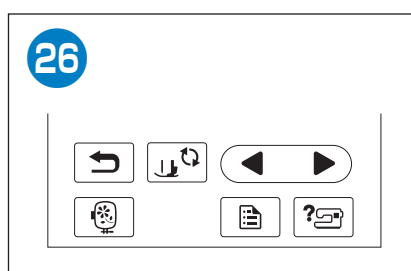
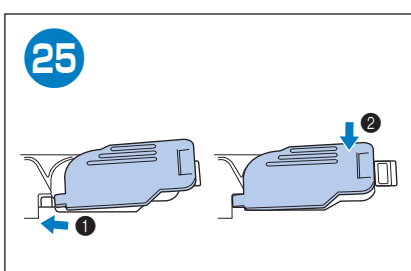
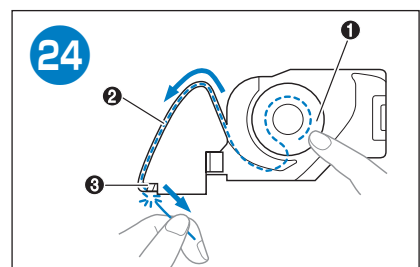
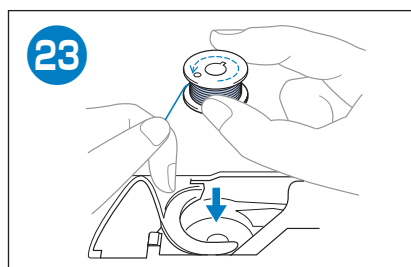
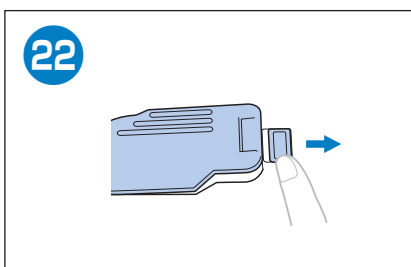
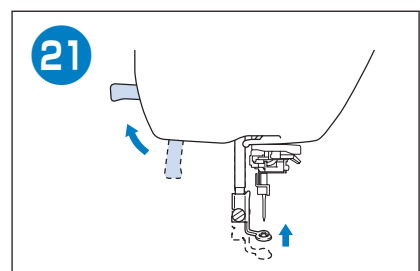
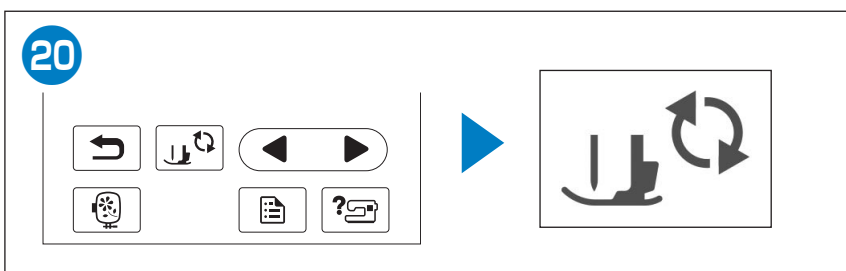
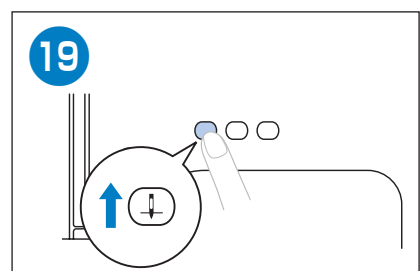
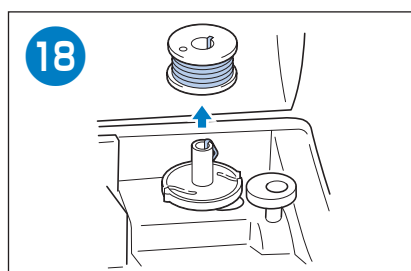
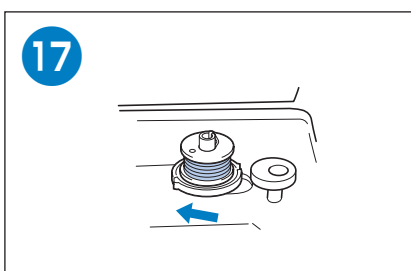
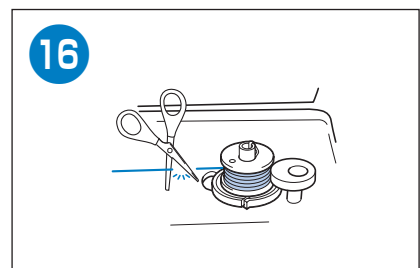
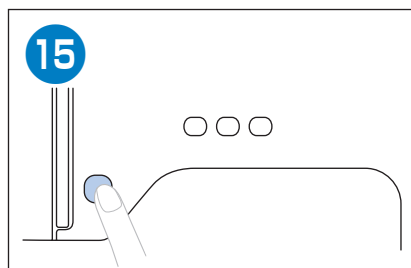
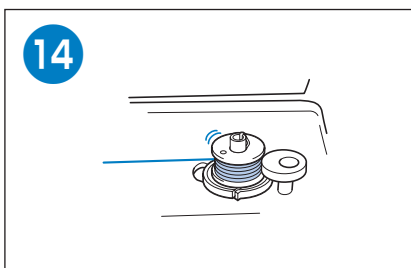
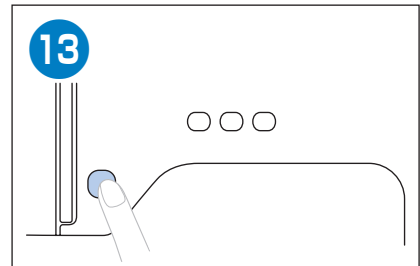
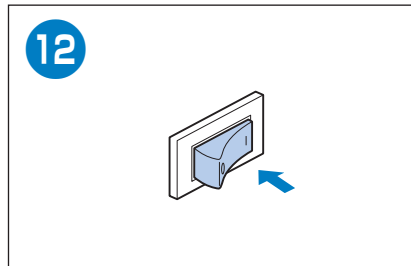
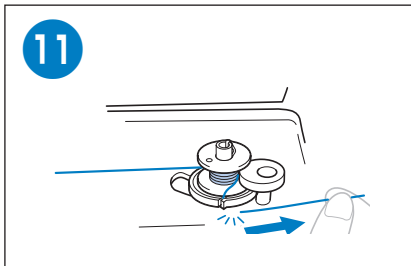
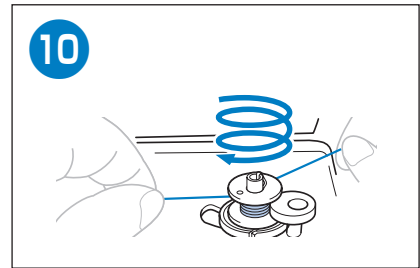
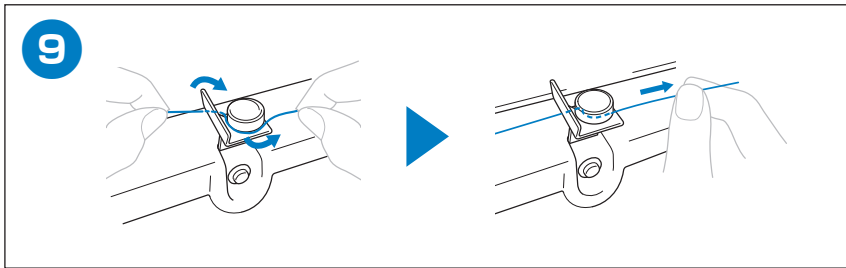

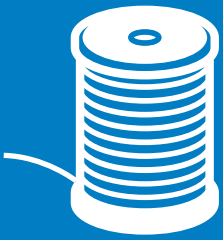

**Upper Threading**  
**Einfädeln des Oberfadens**  
**Enfilage supérieur**  
**Inrijgen van de bovendraad**  
**Infilatura superiore**  
**Hilo superior**  
**Passagem da linha superior**  
**Заправка верхней нити**

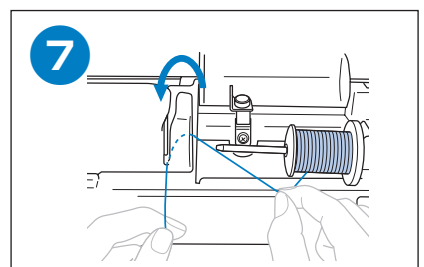
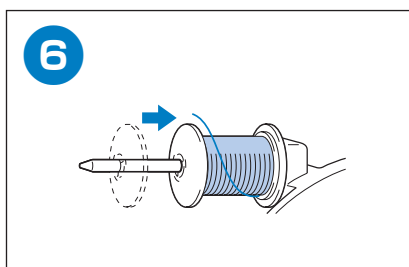
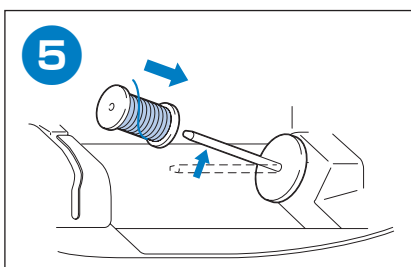
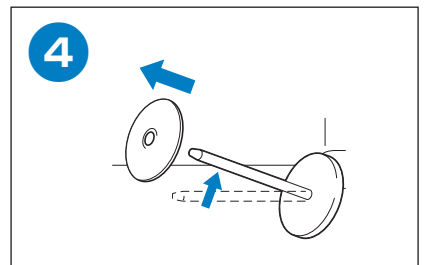
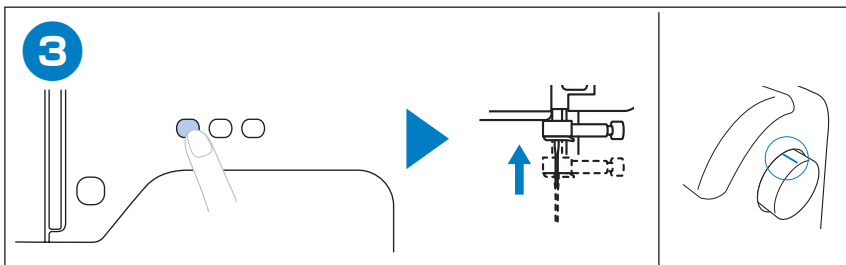
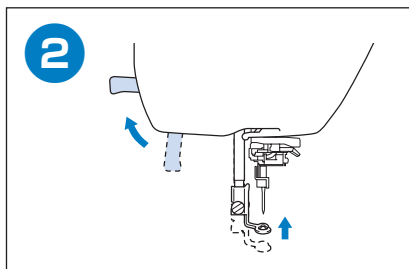
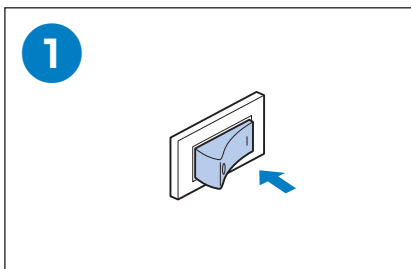
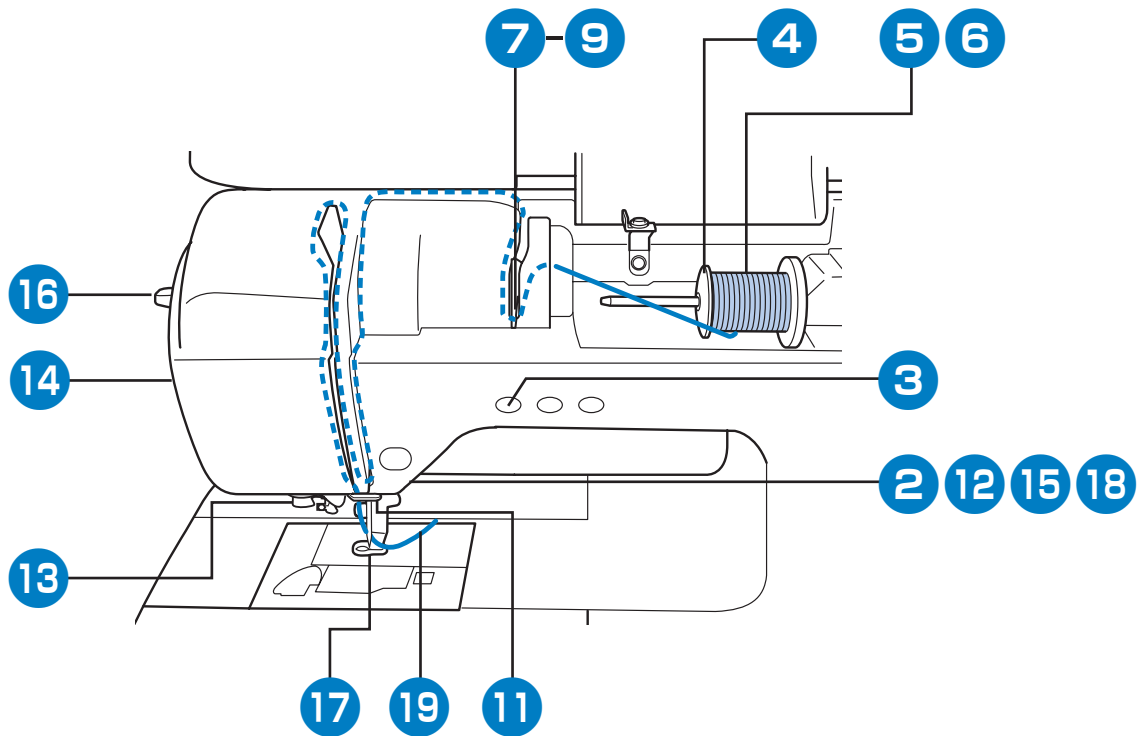

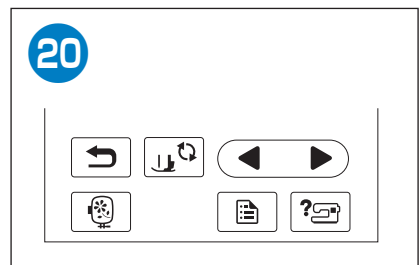
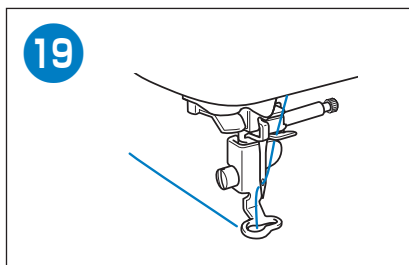
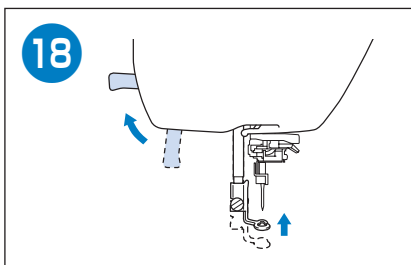
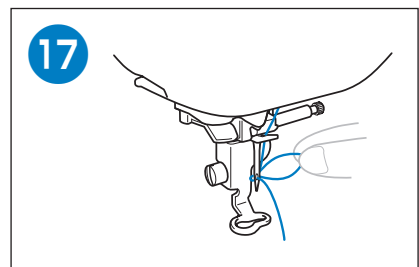
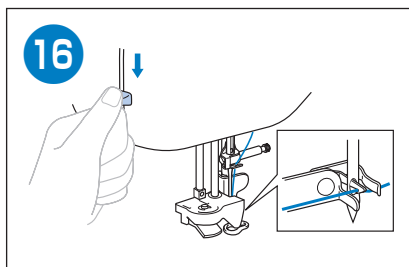
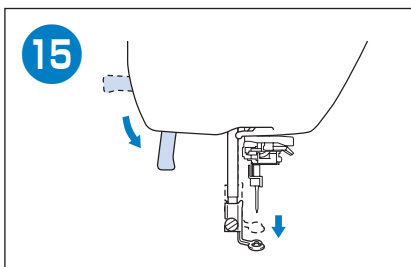
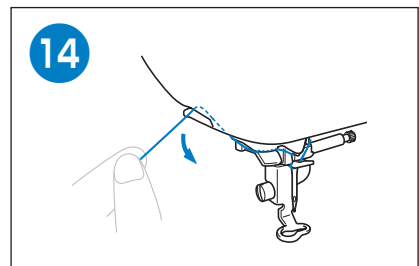
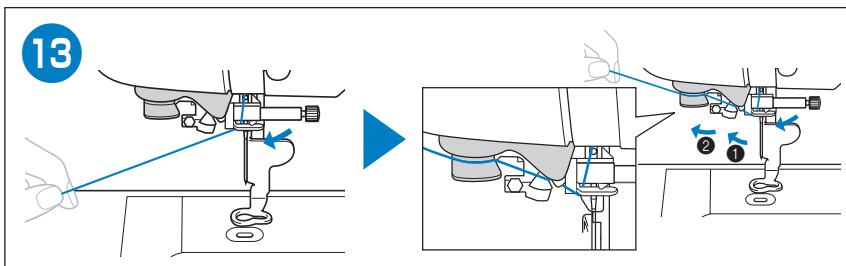
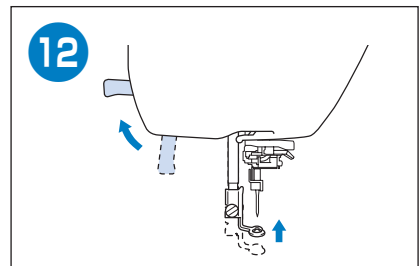
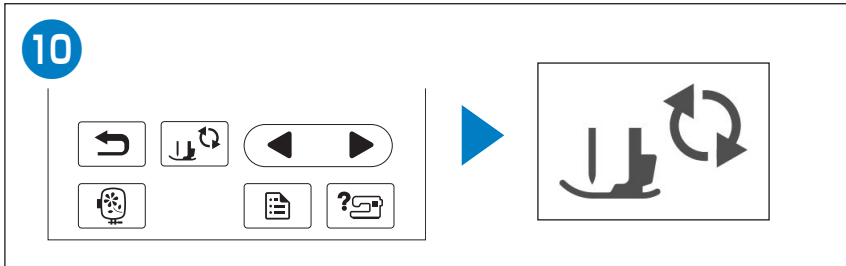
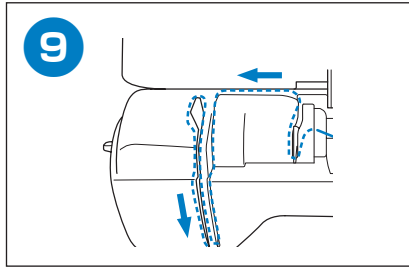
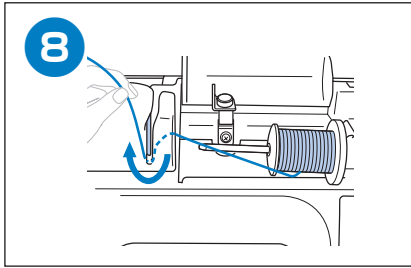





**Preparing to Embroider**  
**Vorbereitung zum Sticken**  
**Préparation de la broderie**  
**Vorbereidingen voor borduren**  
**Preparativi per il ricamo**  
**Preparativos para bordar**  
**Preparaçãõ para bordar**  
**Подготовка к вышиванию**

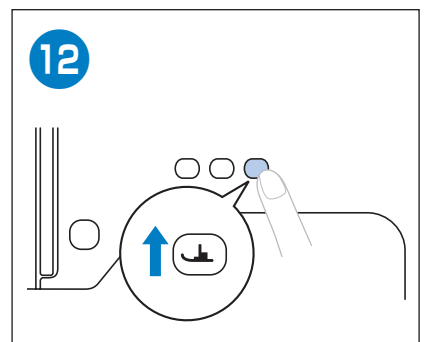
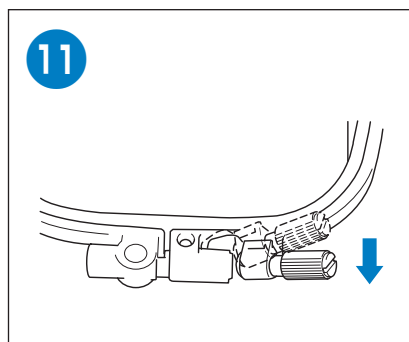
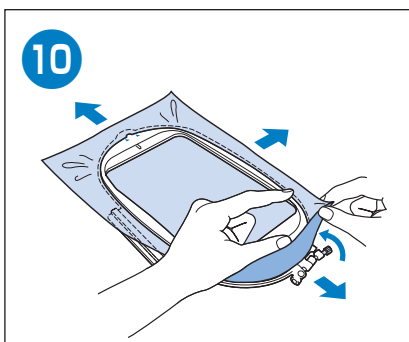
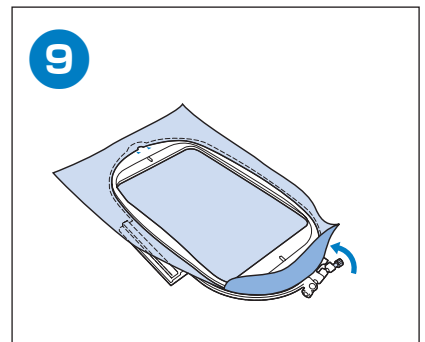
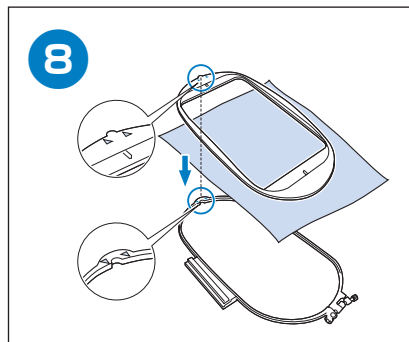
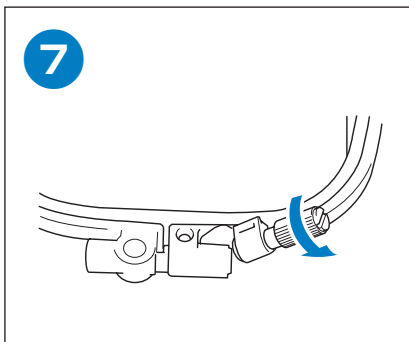
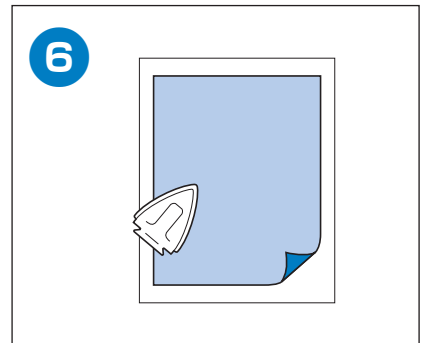
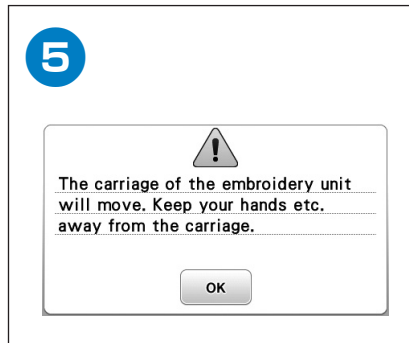
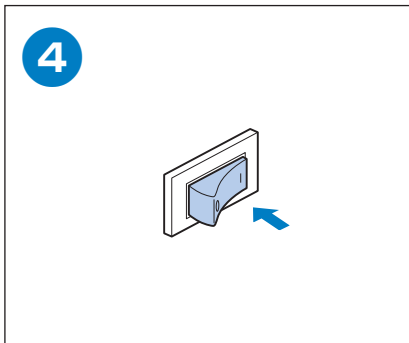
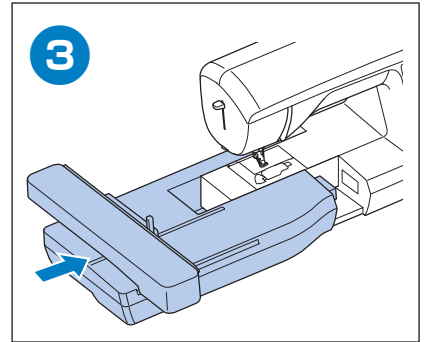
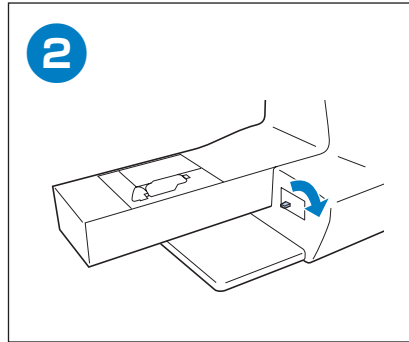
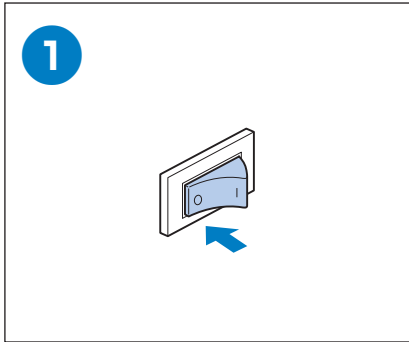

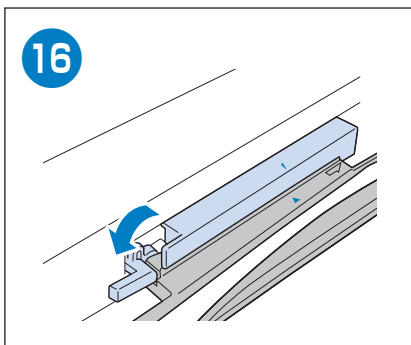
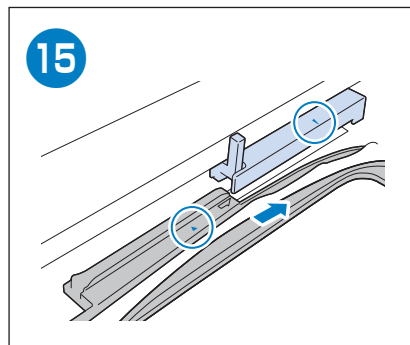
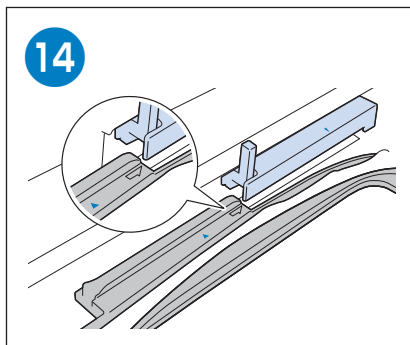
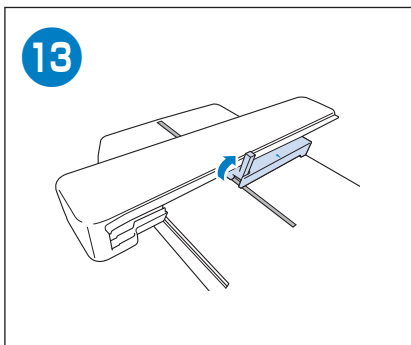



**Selecting Embroidery Patterns**  
**Auswählen von Stickmustern**  
**Sélection des motifs de broderie**  
**Borduurpatronen selecteren**  
**Selezione di ricami**  
**Seleccionar patrones de bordado**  
**Seleção de padrões de bordado**  
**Выбор рисунков для вышивания**

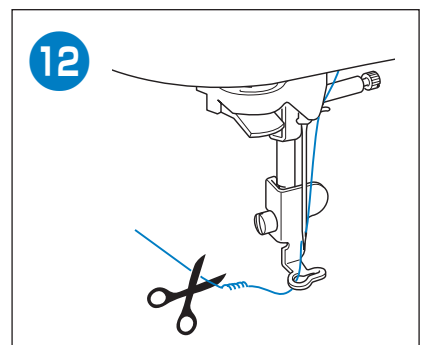
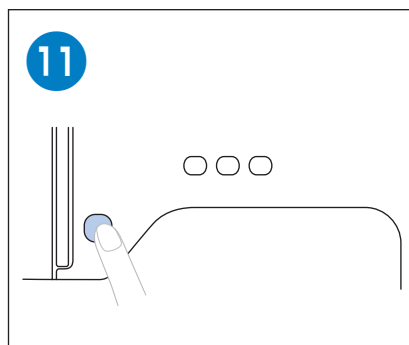
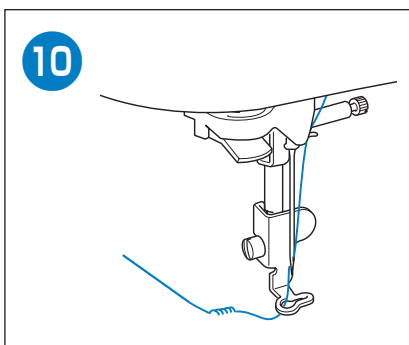
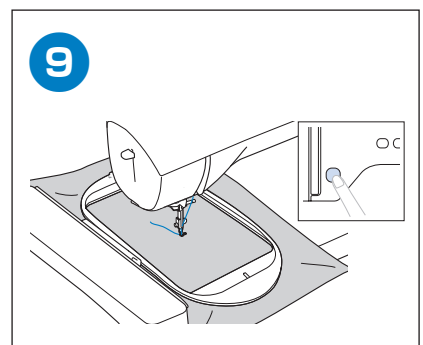
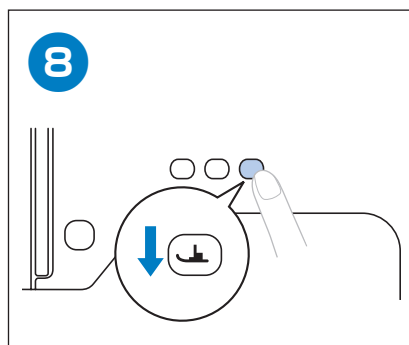
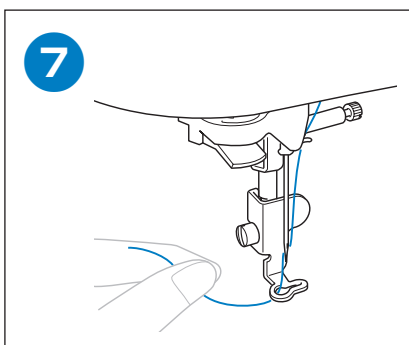
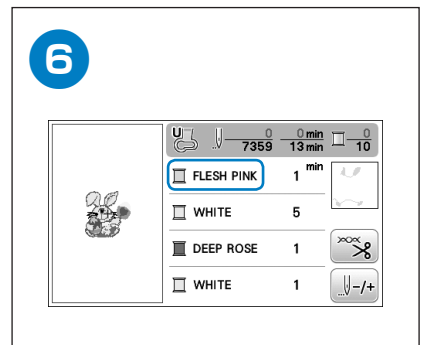
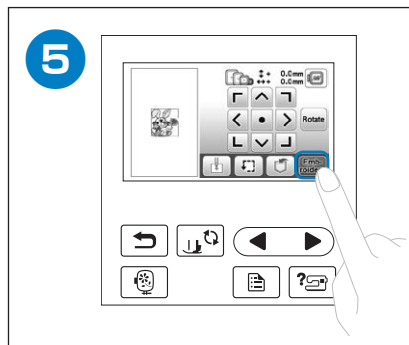
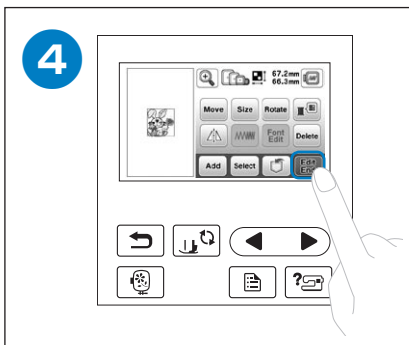
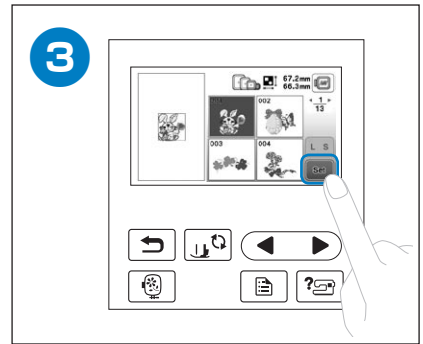
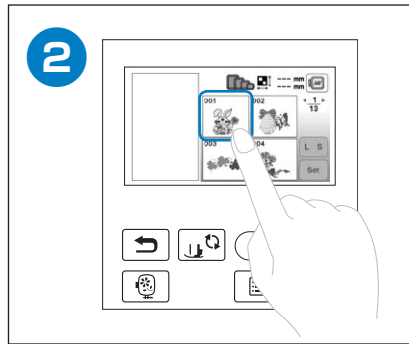
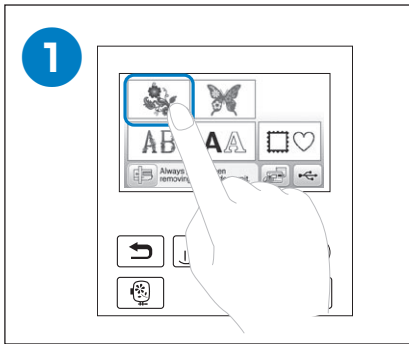

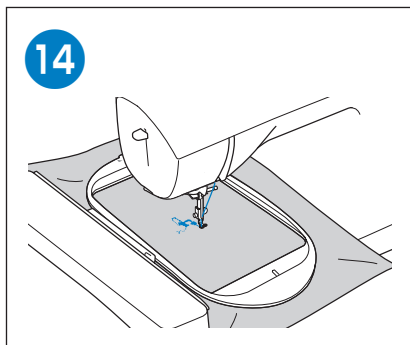
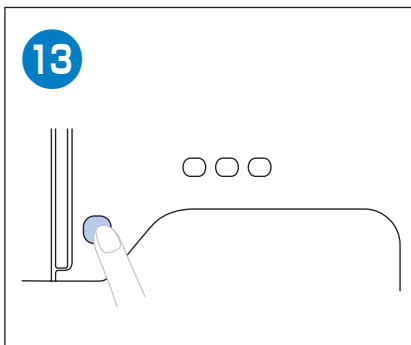

English  
German  
French  
Dutch  
Italian  
Spanish  
Portuguese-BR  
Russian  
888-G80/G82  
Printed in Vietnam



XG0253-001